

200# WOG WAFER STYLE BUTTERFLY VALVE – Lever Handle

Figure: BW-1000 Series



Temperature range of seats	
Material	Range
Buna-N	-12°C~+93°C
EPDM	-30°C~+140°C
Neoprene	-7°C~+107°C
Hypalon	-18°C~+149°C
Viton	-12°C~+140°C
PTFE	-20°C~+121°C

Valves meet MSS-SP67 & API 609

Flange drilling to: ANSI B16.1 Class 125/150

Testing to: API 598

Materials:

No.	Part Name	Specifications	
1	Body	Cast Iron	A126 Class B
2	Disc	Ductile Iron*	A536
3	Stem	Stainless Steel	A433 410
4	Seat	Buna-N	
5	Bushing	PTFE	
6	O-Ring	Buna-N	
7	Position Plate	Carbon Steel*	A27-91 65-35
8	Hand lever	Malleable Iron	A47-90 22010
9	Name Plate	Aluminum Plate	B209-1100
10	Pin	Carbon Steel	

* Nickel plating

Test Pressures	Shell: 300 psi
	Seat: 220 psi

Note: Seat materials are capable of withstanding lower temperatures without damage. However, the elastomer becomes hard and torques increase. Some flow media may further restrict the published temperature limits and/or significantly reduce seat life.

Options:

Seats: Buna-N, EPDM, Hypalon, Viton, Neoprene, PTFE.

Disc: Nickel plated Ductile iron, nylon coated ductile Iron, aluminum bronze, 316 stainless steel.

Body: Cast iron, ductile iron.

Note: Please refer to "Numbering System" sheet to obtain detailed figure numbers.

Caution: All 1000 series valves must be installed in the partial open position. Installing in the full closed position may damage the seat during start up and void any warranties.

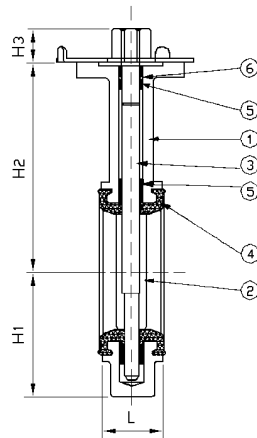
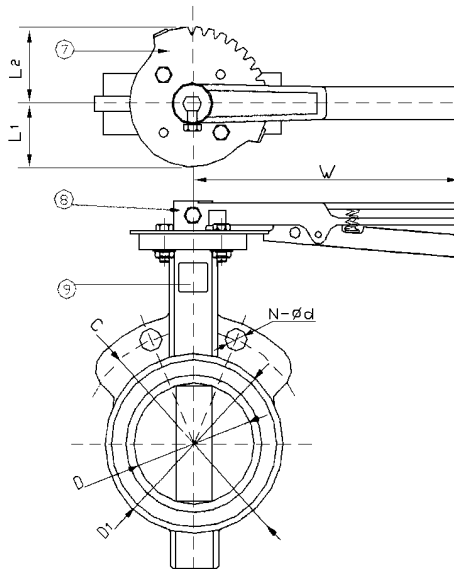

Dimensions:

Size	D		L		H1		H2		H3		Flange			L1	L2	W	Weight							
	in	mm	in	mm	in	mm	in	mm	in	mm	C	D1	N-Ød				in	mm	lb	kg				
2	50	2	51	1.7	43	2.8	71	5.5	140	1.3	33	4.8	120.7	3.7	95	11/16"	1.9	50	2.6	67	10.4	265	8.4	3.8
2½	65	2.5	62.8	1.8	45.8	3.1	78	6	152	1.3	33	5.5	139.7	4.3	109	11/16"	1.9	50	2.6	67	10.4	265	9.25	4.2
3	80	3.1	78	1.8	45.8	3.9	100	6.3	159	1.3	33	6	152.4	5	127	11/16"	1.9	50	2.6	67	10.4	265	10.35	4.7
4	100	4	102.5	2	52	4	102	7	178	1.3	33	7.5	190.5	6	152	11/16"	1.9	50	2.6	67	10.4	265	19.85	9.0
5	125	4.8	121.5	2.2	55.5	4.6	118	7.5	191	1.4	37	8.5	215.9	7.2	182	13/16"	1.9	50	2.6	67	10.4	265	24.05	10.9
6	150	6	154.2	2.2	55.5	5.1	130	8	204	1.37	35	9.5	241.3	8	207	13/16"	1.9	50	2.6	67	10.4	265	31.3	14.2
8	200	7.9	200.9	2.3	59.5	6.4	163	9.4	238	1.7	43	11.8	298.5	10.4	264	13/16"	2.7	70	3.4	87	14	357	40.1	18.2
10	250	9.8	248.9	2.6	67.2	7.8	198	10.6	270	1.5	38	14.3	362	12.5	317	15/16"	2.7	78	3.5	90	14	357	59.1	26.9
12	300	11.8	300	3	77	9.3	235	12.4	315	1.7	43	17	431.8	14.6	370	15/16"	2.7	78	3.5	90	14	357	88.2	40.1